

# Peer-to-Peer Energy Exchanges Model to optimize the Integration of Renewable Energy Sources: the E-Cube Project

Grasso F., Talluri G., Giorgi A., Luchetta L. and Paolucci L.

*Dept. of Information Engineering, University of Florence, Florence, Italy*

*Received: 25 February 2020; Accepted: 30 March 2020; Published: 18 April 2020*

**Abstract**— Future electricity networks will more and more rely on distributed generation and on the increased interaction between consumers and prosumers. In fact, the Renewable Energy Directive recast 2018/2001 has set an important role for the so called “energy communities” which are going to be enabled to produce, consume, store and sell renewable energy. This paper presents a prosumer self-consumption optimization model, working in real-time and in synergy with a peer-to-peer surplus solar electricity sharing model. These models are then applied within a small Energy Community, where the prosumer is also a battery energy storage system (BESS) owner. Test results are presented in terms of technical, environmental and economic benefits and show that peer-to-peer energy trading could improve the local balance of energy generation and consumption. Both models have been developed within E-Cube project activities, participated also by the University of Florence. Other E-Cube project activities include optimal scheduling of household appliances use for demand response, the use of electric vehicles (EVs) as means of energy exchange and the implementation of a blockchain-based “Energy Bank”, used to securely track peer-to-peer energy exchange data.

**Index Terms**— Self-consumption optimization, Peer-to-peer aggregation, Blockchain, prosumers, aggregation, electric storage, peer-to-peer, microgrid.

## ACRONYMS

BESS = Battery Energy Storage System;  
 CNN = Complex Neural Network;  
 CPL = Charging Power Limits  
 DPL = Discharging Power Limits;  
 EMS = Energy Management System;  
 EV= Electric Vehicle  
 DEL = Discharge Energy Limit;  
 LV = Low Voltage;  
 PLPM = Prosumer Load Power Management  
 PV = Photovoltaic plant;  
 REC = Renewable Energy Communities;  
 SCE = Self-consumption efficiency;  
 SOC = State Of Charge;

## I. INTRODUCTION

As distributed renewable energy generation penetration continues to increase within low voltage (LV) networks, the challenges are also mounting. This growing renewable

generation, which is mostly related to customer-owned rooftop solar photovoltaic systems (PV), is also posing issues for the utilities in keeping voltage levels within allowable limits and in correctly matching loads with generation [1]–[5].

Moreover, the electric vehicles (EV) circulating fleet is expected to steeply increase in the years to come, even if forecasts to 2030 propose different scenarios [6]–[8]. EV charging can pose challenges to the electrical grid if not managed correctly; anyway, synergies with PV distributed generation can be exploited if EV smart charging algorithms are put into operation [9].

Within this global framework regulation is evolving and new figures such as the renewable energy communities (REC) are being defined [10], and entitled to “produce, consume, store and sell renewable energy”, “share, within the REC, renewable energy that is produced by the production units owned by that REC” and “access all suitable energy markets both directly or through aggregation”. The possible contribution of IoT devices to the topic are being explored [11], [12], and peer-to-peer energy exchange models are being defined, e.g. [13]–[16].

The Italian R&D project “E-Cube” is led by a major electrical energy provider and is participated by several technical partners. Scope of the project is to develop an innovative energy exchange system operating within a number of selected provider’s customers. Some of the main features of the prototypal system, which high-level architecture is shown in Fig.1, are:

- 1) to increase customers observability and flexibility by providing them with smart meters and IoT devices for the remote and automated load control;
- 2) to develop optimal scheduling models for household appliances use, with demand response purposes;
- 3) to promote the use of EVs as means of energy exchange within the customers and as distributed BESSs;
- 4) to develop and put into operation a blockchain-based “Energy Bank”, used to securely track peer-to-peer energy exchange data within E-Cube participants;
- 5) in perspective, to provide ancillary services to the grid [17]–[20];
- 6) in perspective, to optimize day-ahead market and real-time market purchases of the service provider.

To comply with this last task, the University of Florence is developing ad-hoc complex neural networks (CNN), based on the extensive experience of the Dept. of Information Engineering on this topic [21]–[23].

to appropriately share prosumer PV surplus energy, within the involved energy community, both directly and through the use of the BESS. The second part defines the set-up used for the simulation and evaluate the results obtained, using a set of techno-economic and environmental indicators.

## II. MODEL DESCRIPTION

These models have been developed having in mind locally-based RECs, where both prosumers and consumers are geographically close to each other and possibly connected to the same LV feeder and served by the same transformer. As an example, prosumers and consumers could be households located in the same neighborhood or even in the same building [3], [9], [15], [25]. The simultaneity of PV power generation and load requests, which is mandatory for the energy transaction to be completed, is granted by the combined use of local smart-meters and centralized, blockchain-secured, database [26].

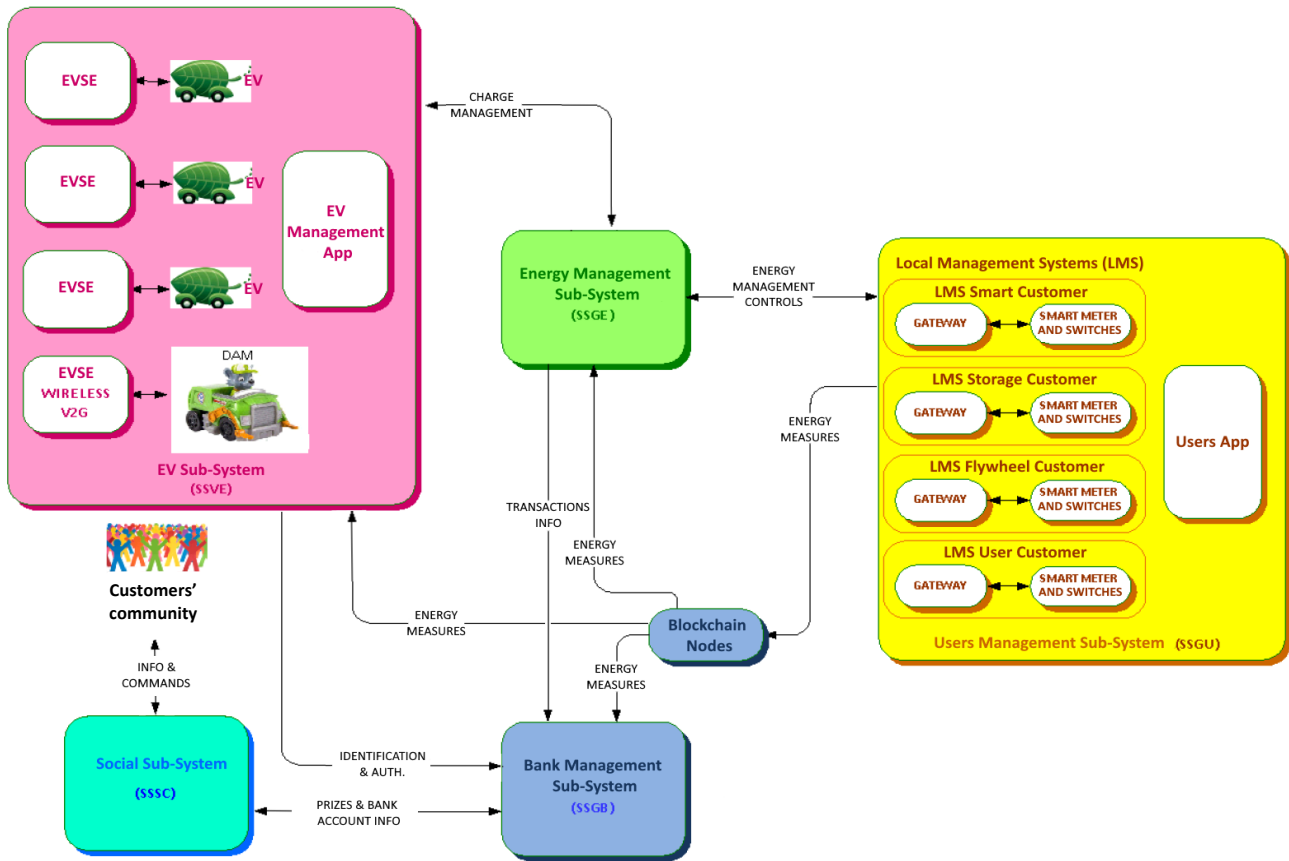

Fig. 4. E-Cube System high-level structure where EVSE is the Electric Vehicle Supply Equipment and V2G is the Vehicle to Grid.

Within the project, the University of Florence was also in charge for the development of appropriate optimization algorithms for load control and management. This paper presents part of the results obtained during the project, specifically focusing on the developed energy community management strategies [24].

The paper is organized as follow: the first part describes the models and the algorithms regulating prosumer self-consumption optimization and the transaction strategies defined

The installed smart meters acquire data with 1-second resolution, while the model is applied over one day with a 1-minute timestep. All the values of interest for the model are then averaged over each of the 1-minute periods considered, before being used. As a convention, within this model load power is considered positive and generation power negative. Following the same convention, BESS charging power  $P_{BC}(t)$  is considered positive and discharging power  $P_{BD}(t)$  negative; charging power limits (CPL) and discharging power limits

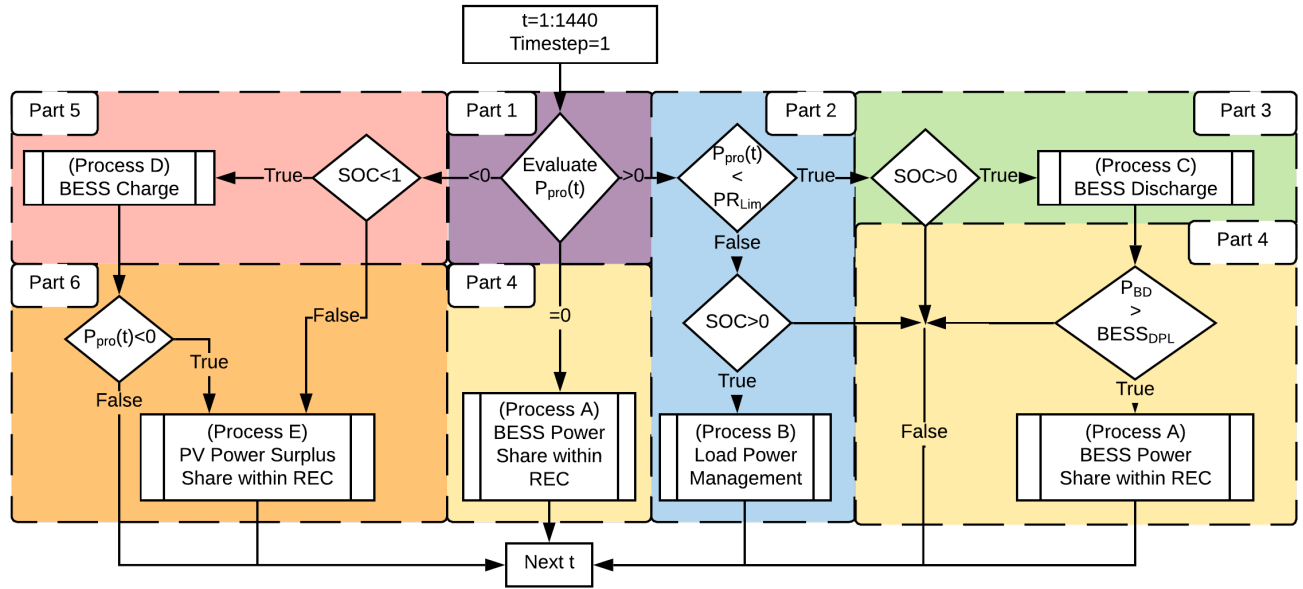

Fig. 5. Model processes algorithm high-level structure

(DPL) are imposed by  $BESS_{CPL}$  and  $BESS_{DPL}$ , respectively. BESS is considered a lossless storage system, with a unit round-trip yield, for the purpose of this simulation; moreover, its capacity  $BESS_{size}$  is considered as net and fully usable. No explicit constraints are set on power exchanges of prosumer and consumers with the grid, both load- and PV-related. This choice is related to the existence of implicit constraints related to the contractual agreements already in place between consumers and grid operator or service providers, that shape and limit load and generation power curves [18], [20].

All the power-related variables, such as loads power consumption, PV power generation, BESS charge and discharge power and power exchanges through the REC are related to a specific timestep. Energy related variables, such as BESS capacity and state of charge (SOC) are inherited from previous timestep at the beginning of each timestep and then updated accordingly to the power exchanges occurred.

Starting from the previous considerations, it is therefore possible to implement the system management algorithm. The transaction pathways are defined in Fig. 1, while the global structure of model processes and underlying algorithm is shown in Fig.2, where the six main parts are highlighted. In the following, all of the main parts of the algorithm are explained in-depth. The model, for sake of simplicity is applied to a single prosumer and to a plurality of consumers. Anyway, it can be extended to a REC with also a plurality of prosumers simply stacking together the single contributions and creating a “Prosumer Aggregator”. Besides that, the total energy transaction involving the aggregator would then be proportionally shared between the prosumers.

#### A. Part 1: Prosumer characterization

The first part of the algorithm defines – for each timestep  $t$  – if the Prosumer is either a net power producer, a net load or is idle with respect to the grid. To do so, it solves

$$P_{pro}(t) = P_{pV}(t) + L(t) \quad (1)$$

where  $P_{pro}(t)$  is the net power of the prosumer,  $L(t)$  is the total load and  $P_{pV}(t)$  is the total solar PV generation, all expressed in kW. Based on the above power condition, the algorithm can proceed in three ways:

1. if  $P_{pro}(t) > 0 \rightarrow$  Part 2;
2. if  $P_{pro}(t) = 0 \rightarrow$  Part 4;
3. if  $P_{pro}(t) < 0 \rightarrow$  Part 5.

#### B. Part 2: Prosumer load power management

If  $P_{pro}(t) > 0$  the prosumer is a net load for the grid; the EMS then checks if the contractual power limits  $Pr_{lim}(t)$  are respected, by evaluating if  $P_{pro}(t) < Pr_{lim}$ .

If the  $Pr_{lim}$  threshold is surpassed and the BESS state of charge is higher than zero, the prosumer load power management (PLPM) process is activated, aiming at reducing prosumer’s consumption under the threshold. At first, *Process B*, described in Table I, checks  $SOC(t)$ .

If  $SOC(t) \leq 0.5$ , it allows only a limited discharge of BESS on the load with power  $P_{BD}(t)$  just to reduce prosumer’s power consumption and bring it back to below contractual power limit:

$$|P_{BD}(t)| = \min[(P_{pro}(t) - Pr_{lim}), \quad (2)$$

$$|BESS_{DPL}|, |BESS_{DEL}(t)|],$$

where  $BESS_{DPL}$  is the discharge power limit of BESS and  $BESS_{DEL}(t)$  is the discharge energy limit of BESS, which is the discharge power that brings the state of charge of BESS to zero within the timestep, starting from the conditions in  $t-1$  and is defined by:

TABLE I  
PROSUMER LOAD POWER MANAGEMENT PROCESS

Process B	
Prosumer Load Power Management	
1	<b>If</b> $SOC(t) < 0.5$
	Then $\rightarrow$ BESS is used to reduce $P_{pro}(t)$ to below contractual power limit $P_{r_{lim}}$
2	<b>else</b>
	Process C (BESS Discharge)
3	<b>If</b> $P_{BD}(t) > BESS_{DPL}$
	Then $\rightarrow$ Process A (BESS Power Share within REC)
4	<b>end If</b>
5	<b>end If</b>
6	Update all the involved variables

TABLE II  
BESS DISCHARGE PROCESS

Process C	
BESS Discharge	
1	Evaluate max exchangeable power and energy from BESS
	As described in (2) and (3)
2	<b>If</b> $P_{BD}(t) = P_{pro}(t)$
	Then $\rightarrow$ Set $P_{pro}(t) = 0$
3	<b>else</b>
	Then $\rightarrow$ Set $P_{pro}(t) = P_{pro}(t) - P_{BD}(t)$
4	<b>end If</b>
5	Update all the involved variables

TABLE III  
BESS POWER SHARE WITHIN REC PROCESS

Process A	
BESS Power Share within REC	
1	Define BESS available energy and Power for REC share
	As defined in (4)
2	<b>If</b> $BESS_{AVE}(t) > 0$ AND $BESS_{AVP}(t) > 0$
	Then $\rightarrow$ Share $P_{BS}(t)$ proportionally within REC Consumers
3	<b>end If</b>
4	Update all the involved variables

TABLE IV  
BESS CHARGE PROCESS

Process D	
BESS Charge	
1	Evaluate max BESS charging power and energy from PV
	As described in (6) and (7)
2	Charge BESS
3	Update all the involved variables

$$BESS_{DEL}(t) = -(BESS_{size} * SOC(t - 1) * 60) \quad (3)$$

where  $BESS_{size}$  is the size of prosumer's storage system.

TABLE V  
PV POWER SURPLUS SHARE WITHIN REC PROCESS

Process E	
PV Power Surplus Share within REC	
1	Evaluate $P_{PVS}(t)$ , the maximum PV surplus power shareable within REC.
	As defined in (8)
2	Share $P_{PVS}(t)$ proportionally within REC Consumers.
3	<b>If</b> $(P_{pro}(t) - P_{PVS}(t)) < 0$
	Then $\rightarrow$ Sell to grid operator
4	<b>end If</b>

Limiting BESS discharge power requests allows to preserve enough BESS capacity to cope with longer periods of threshold surpassing.

If  $SOC(t) > 0.5$ , *Process B* enables at first *Process C* (described in Table II), which allows an unrestricted BESS discharge on prosumer's load  $P_{pro}(t)$  with the purpose to bring consumption to zero:

$$|P_{BD}(t)| = \min[P_{pro}(t), |BESS_{DPL}|, |BESS_{DEL}(t)|] \quad (4)$$

Then, if BESS has not yet reached its discharge power limit  $BESS_{DPL}$  or its discharge energy limit  $BESS_{DEL}(t)$ , it enables *Process A* (described in Table III) which defines BESS power share within REC.

Once the processes are completed, net prosumer consumption  $P'_{pro}(t)$  and BESS state of charge  $SOC(t)$  are updated:

$$P'_{pro}(t) = P_{pro}(t) + P_{BD}(t) \quad (5)$$

$$SOC(t) = SOC(t - 1) + \frac{P_{BD}(t)}{60'} * \frac{1}{BESS_{size}}. \quad (6)$$

### C. Part 3: BESS discharge management

In order for *Process C* to be activated, the prosumer must act as a net load for the grid; the EMS then evaluates the power to be exchanged by BESS with prosumer load  $P_{BD}(t)$  as defined in (4). Then the discharge process is enabled, and *Process C* is completed.

### D. Part 4: BESS power share within REC

Part 4 of the algorithm is enabled by two specific conditions:

1. when the prosumer is idle with respect to power exchanges with the grid and  $SOC(t) > 0$
2. after *Process C* completion, if  $P_{BD}(t) > BESS_{DPL}$ .

As the first step, *Process A* (described in Table III) evaluates the amount of available energy and power to be shared within the consumers of the REC, respectively  $BESS_{AVE}(t)$  and  $BESS_{AVP}(t)$ , defined as:

$$\begin{cases} BESS_{AVE}(t) = -(BESS_{size} * SOC(t) * BESS_{share}) \\ BESS_{AVP}(t) = BESS_{DPL} - P_{BD}(t) \end{cases} \quad (7)$$

where  $BESS_{Share}$  is the percentage of BESS capacity made available at every timestep to be shared with REC. Taking into account all of the simulation parameters,  $BESS_{Share}$  has been set to a 1% value. Successively, if energy and power from BESS are effectively available to share, power  $P_{BS}(t)$ :

$$P_{BS}(t) = \min[P_{AC}(t), BESS_{AVE}(t), BESS_{AVP}(t)] \quad (8)$$

where  $P_{AC}(t)$  represents the total load power of all REC consumers at timestep  $t$ , is shared between the REC consumers, proportionally with the power absorbed from the grid by the loads of each one during timestep  $t$ . Once the process is completed, BESS SOC is updated::

$$SOC(t) = SOC(t-1) + \frac{P_{BS}(t)}{60'} * \frac{1}{BESS_{size}} \quad (9)$$

#### E. Part 5: BESS charge management

As reported in Fig.2, *Process D* (described in Table IV) is enabled when the prosumer acts as a net power producer, thus when  $P_{pro}(t) < 0$  and  $SOC(t) < 1$ . If both conditions are true, BESS is charged with power  $P_{BC}(t)$ , defined as:

$$P_{BC}(t) = \min[P_{pro}(t), BESS_{CPL}, BESS_{CEL}(t)] \quad (10)$$

where  $BESS_{CPL}$  is the power limit for BESS charging and  $BESS_{CEL}(t)$  represents BESS charge energy limit, which is the charge power that completely charge the BESS within the timestep starting from the conditions in  $t-1$ :

$$BESS_{CEL}(t) = (BESS_{size} * (1 - SOC(t-1))) * 60. \quad (11)$$

Once the processes are completed, net prosumer generation is updated:

$$P'_{pro}(t) = P_{pro}(t) + P_{BC}(t); \quad (12)$$

and BESS SOC is updated:

$$SOC(t) = SOC(t-1) + \frac{P_{BC}(t)}{60'} * \frac{1}{BESS_{size}}. \quad (13)$$

#### F. Part 6: PV surplus power share within REC

Part 6 of the algorithm, thus *Process E* (described in Table V), is enabled by two specific conditions:

1. when the prosumer is a net generator with respect to power exchanges and  $SOC(t) = 1$ , so BESS is not available to store PV surplus energy
2. after Process D completion, if  $P'_{pro}(t) < 0$ , thus PV surplus power is still available.

As with *Process A*, the first step of *Process E* evaluates the maximum amount of PV surplus power  $P_{PVS}(t)$  that can be shared within REC consumers, as defined in:

$$|P_{PVS}(t)| = \min [P_{AC}(t), |P'_{pro}(t)|] \quad (14)$$

Once  $P_{PVS}(t)$  is defined, power is shared between the REC consumers, proportionally with the consumptions of each one during timestep  $t$ .

Finally, if there is any PV power surplus  $P''_{pro}(t)$  left:

$$P''_{pro}(t) = P'_{pro}(t) - P_{PVS}(t) \quad (15)$$

it is sold to the grid operator.

### III. SIMULATION

#### A. Case study definition

The above-defined model has been used to simulate energy exchange occurring within a small REC, composed by 1 prosumer and 3 consumers, which are all typical residential users, over a single day. For this case study, the prosumer is equipped with a PV generation unit rated for 3kW peak power, a BESS with 6 kWh of net capacity, capable of charging and discharging with a power of up to 3kW and with non-controllable loads. The consumers are only equipped with non-controllable loads; both consumers and prosumer are entitled of electricity contracts with service operator for a continuous maximum power of 3 kW.

Both the load profiles and the PV generation profiles used for the simulation are real datasets, acquired as an E-cube project activity; as already reported in section II, both power profiles have a 1-minute resolution. The simulation is run on both Matlab and Simulink environment and uses 12 days of consumption data for both consumers and prosumer and 6 days of PV generation data. The latter have been chosen among different periods of the year and different weather situation, in order to evaluate a comprehensive array of situation within the simulation. This leads to a total of 72 different days of data, among which the simulation runs recursively, with a 1-day period. In order to grant test repeatability, the BESS is set to be at  $SOC = 0$  at the beginning of every period. BESS state of charge could be higher than zero at the end of some simulation days; this is an effect of the combination of load requests, PV generation availability and, lastly, BESS size. This indeed leads to a techno-economic inefficiency, since part of BESS capacity is not utilized. Anyway, even if the presented model could as well be used for techno-economic BESS sizing, this is out of the scope for this simulation. Instead, it focuses on the analysis and quantification of possible advantages emerging from prosumer-consumers energy transactions within a REC.

#### B. Analyzed scenarios

Within this simulation, two scenarios have been analysed: a “*Baseline*” scenario, where the optimization algorithm is applied only to the prosumer and a “*REC*” scenario, where the optimization algorithm is applied to the whole energy community. More precisely, in the *Baseline* scenario only Part 1,2,3 and 5 of the algorithm are implemented (see Fig. 2); the BESS charges to recover PV surplus and discharges to supply load and eventual power contractual limits surpassing. Consumers power their loads using only grid electricity.

In *REC* scenario the algorithm is fully implemented, and both prosumer’s PV power surplus and BESS energy surplus are

shared with the other consumers. Prices and actor of the various possible energy transactions considered for this simulation are defined in Table VI and are referred at the typical Italian environment, but can be considered as a reference for further considerations.

TABLE VI  
DESCRIPTION OF ENERGY TRANSACTION TYPES

Transaction Type	Price	Seller	Buyer
Electricity Purchase from Grid	0.24 €/kWh	Service Provider	Prosumer Consumers
PV Net Metering Sale	0.08 €/kWh	Prosumer	Service Provider
PV Share within REC	0.16 €/kWh	Prosumer	Consumers
BESS Share within REC	0.16 €/kWh	Prosumer	Consumers

The prices of both PV share and BESS share within REC are defined as the average of purchase price of electricity from the service provider and PV net metering sale price to the service provider [27]. Capital costs of PV and BESS installation are not considered in this simulation because the extension of the grid is such as to lead to results that are inconsistent with the application, which must take place in wider contexts. Furthermore, among the project hypotheses there is the evaluation of the implementation of what is proposed in areas where the installation of renewable energies and storage batteries (or EVs) will be mandatory due to pollution areas or congestion areas.

### C. Performance indicators definition

In order to evaluate simulation results, a series of indicators has been defined. Some of them are defined as the variation ratio between *Baseline* and *REC* scenarios and are identified by subscript “*var*”; others are defined by the simple difference between the two scenarios, identified by the subscript “*Diff*”. Finally, some are defined by the value assumed in the *REC* scenario and are identified by the subscript “*REC*”.

Prosumer savings  $PS_{var}$  or earnings increase ratio between the scenarios is defined as:

$$PS_{var} = \frac{PS_{REC} - PS_{Base}}{PS_{Base}} \quad (16)$$

where  $PS_{Base}$  is the prosumer saving in the *Baseline* scenario, while their net amount  $PS_{Diff}$  is described by:

$$PS_{Diff} = PS_{REC} - PS_{Base} \quad (17)$$

In the same way, consumers savings are defined by  $CS_{var}$  and  $CS_{Diff}$ . grid dependency reduction ratio between scenarios is instead defined by  $GD_{var}$ , while its value in the *REC* scenario is defined by  $GD_{REC}$ .

Self-consumption efficiency (SCE) is defined as the ratio between the reduction of energy purchase from the grid and the PV total energy generation. For the *Baseline* scenario the reduction of energy purchase from the grid is related only to the prosumer and is defined as  $SCE_{pro}$ , while for the *REC* scenario it is related to the whole REC and is defined as  $SCE_{REC}$ . Following these definitions,  $SCE_{var}$  is described by:

$$SCE_{var} = \frac{SCE_{REC} - SCE_{pro}}{SCE_{pro}} \quad (18)$$

CO<sub>2</sub> savings related to the reduction of energy purchase from the grid are directly proportional to it; the 2013 CO<sub>2</sub> intensity of Italian Fuel Mix [24] for electricity production has been used for calculation, for a value of 343 gCO<sub>2</sub>eq/kWh.

The kWh of PV surplus energy non-allocated within the REC at the end of the day of simulation are reported by  $PVL_{REC}$ ; finally, the kWh amount of PV-related energy shared within the REC is defined by  $SE_{REC}$ .

### D. Results

Fig. 3 shows in the upper graph the typical values assumed in *Baseline* scenario over a simulation day by the main prosumer variables, such as  $SOC(t)$ , Net PV power  $P_{pro}(t)$ ,

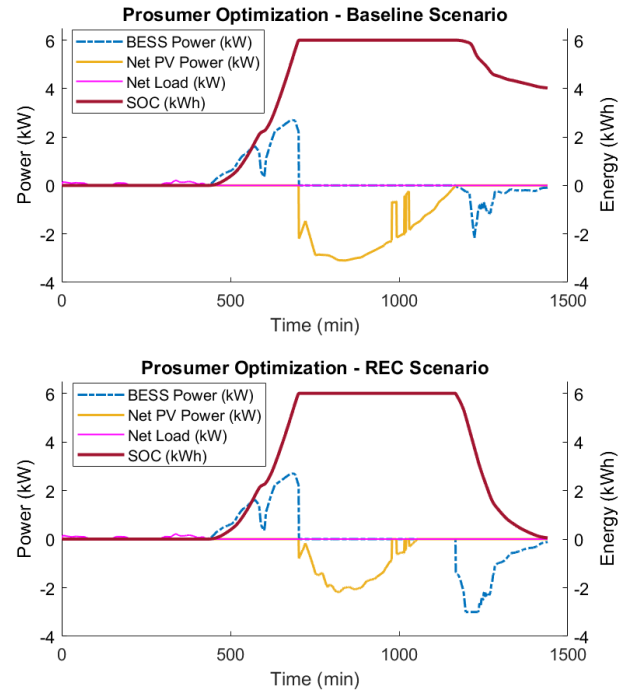

Fig. 6. Prosumer main Power and Energy flows in the two considered scenarios over one single day

BESS charge and discharge power  $P_{BC}(t)$  and  $P_{BD}(t)$  and prosumer net load power  $P_{pro}(t)$ ; in the lower graph the same variables are reported for the same simulation day but in the *REC* scenario. SOC reduction at the end of the day is evident, as well as the overall reduction of PV surplus power. This is one of the main results of the energy exchanges taking place within the REC and it directly leads to a raise in prosumer’s earnings. Fig. 4 shows  $SOC(t)$  and  $P''_{pro}(t)$  trends over the all the 72 analysed 1-day periods, for both scenarios. It stands out clearly from the graphs that BESS end-of-the-day SOC is constantly reduced in the *REC* scenario when compared with *Baseline*; this confirms that the algorithm performs correctly throughout all the analysed situations. Looking at the graphs on the right side, it can be noted how PV power surplus left after optimization is thoroughly reduced in the *REC* scenario throughout all the periods.

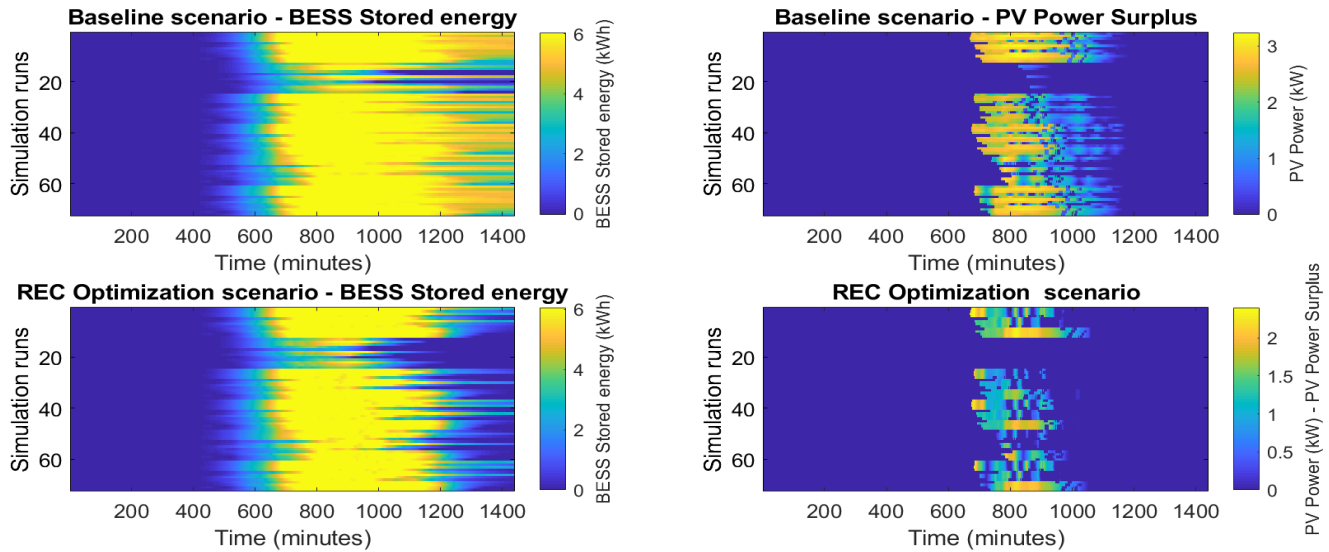

Fig. 4. BESS state of charge level and PV power surplus after REC share, over the various simulation days.

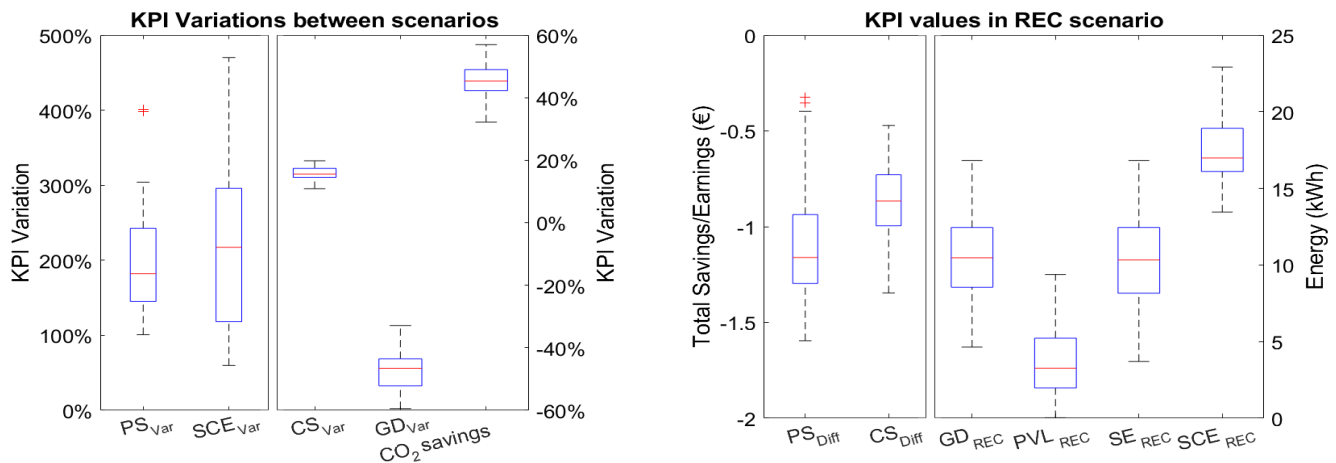

Fig. 5. Boxplot showing median (red line), extremes data points (whiskers) and outliers (red crosses) of the main indicators analysed

One side-effect related to the use of a part of BESS capacity for energy exchanges within the REC is a possible small increase in prosumer’s energy purchase from the grid; anyway, the economic balance of prosumer improves when passing from *Baseline* to *REC* scenario, as can be noted in Fig. 5, where an analysis of indicator values gives an overview on the improvements related to the implementation of the proposed REC model: first of all, the dependency on the grid for electricity is reduced, on average, by more than 40%, and CO<sub>2</sub> savings share is increased accordingly. In absolute terms this translates in an average of around 10 kWh/day of electricity that is shared within the community. Moreover, self-consumption increases more than two-fold, on average, passing from the baseline scenario in which only prosumer is involved in the optimization, to the REC scenario where also consumers are. This translates into more than 15 kWh/day self-consumed within the REC, of which around 10 kWh/day are shared – as

already stated – and the rest is used by the prosumer.

Taking into account the economics of the operation, they result to be quite positive, since prosumer’s earnings in *REC* scenario are nearly two-fold than in the *Baseline*, on average, and consumers savings are around 15÷20%. As stated before, capital costs of prosumer’s PV and BESS installation are not considered in this simulation, so the real prosumer’s earnings have to be expected to be reduced by some extent. Finally, it is necessary to keep in mind that, based on the optimization process adopted, the energy that can lead to the saturation of the single prosumer is lost energy, while all the energy that would lead to saturation the REC is actually energy shared with all consumers.

#### IV. CONCLUSIONS

Within this work, a REC energy management and exchange

optimization model has been presented. In the model, a service provider, acting as an aggregator, is monitoring a local energy community. Both the energy productions and load requests are tracked down into a blockchain-secured cloud database. This allows to detect simultaneously both load requests and PV production, so to correctly assess energy and economic transactions between users. The model functionality has then been simulated, using real load and PV production data, over a 72 days period. Simulation results show that the proposed model reduces grid dependency of the REC, thanks to the improved rates of PV self-consumption and local energy exchanges. Also, simulation shows that both prosumer and consumers improve their economic parameters: on average the first doubles its earnings while the latter saves around 15-20%.

#### ACKNOWLEDGMENT

Part of this work was supported by the *Regione Toscana* under POR FESR Toscana 2014-2020 ASSE 1 AZIONE 1.1, Project E-CUBE CUP D51B17002280009.

#### REFERENCES

- [1] P. Mancarella, D. Randles, A. Navarro, and L. F. Ochoa, "Impacts of photovoltaics on low voltage networks: a case study for the north west of England," in *22nd International Conference and Exhibition on Electricity Distribution (CIRED 2013)*, 2013, pp. 1419–1419.
- [2] A. T. Procopiou, C. Long, and L. F. Ochoa, "On the effects of monitoring and control settings on voltage control in PV-rich LV networks," in *2015 IEEE Power & Energy Society General Meeting*, 2015, pp. 1–5.
- [3] E. Quiles, C. Roldán-Blay, G. Escrivá-Escrivá, and C. Roldán-Porta, "Accurate Sizing of Residential Stand-Alone Photovoltaic Systems Considering System Reliability," *Sustainability*, vol. 12, no. 3, p. 1274, Feb. 2020.
- [4] O. Babacan, E. L. Ratnam, V. R. Disfani, and J. Kleissl, "Distributed energy storage system scheduling considering tariff structure, energy arbitrage and solar PV penetration," *Appl. Energy*, vol. 205, pp. 1384–1393, Nov. 2017.
- [5] G. Masson and I. Kaizuka, "IEA PVPS report - Trends in Photovoltaic Applications 2019," 2019.
- [6] R. Fachrizal and J. Munkhammar, "Improved Photovoltaic Self-Consumption in Residential Buildings with Distributed and Centralized Smart Charging of Electric Vehicles," *Energies*, vol. 13, no. 5, p. 1153, Mar. 2020.
- [7] F. Giordano, A. Ciocia, P. Di Leo, F. Spertino, A. Tenconi, and S. Vaschetto, "Self-Consumption Improvement for a Nanogrid with Photovoltaic and Vehicle-to-Home Technologies," in *2018 IEEE International Conference on Environment and Electrical Engineering and 2018 IEEE Industrial and Commercial Power Systems Europe (EEEIC / I&CPS Europe)*, 2018, pp. 1–6.
- [8] Talluri, Grasso, and Chiamonti, "Is Deployment of Charging Station the Barrier to Electric Vehicle Fleet Development in EU Urban Areas? An Analytical Assessment Model for Large-Scale Municipality-Level EV Charging Infrastructures," *Appl. Sci.*, vol. 9, no. 21, p. 4704, Nov. 2019.
- [9] E. Sortomme and M. A. El-Sharkawi, "Optimal Scheduling of Vehicle-to-Grid Energy and Ancillary Services," *IEEE Trans. Smart Grid*, vol. 3, no. 1, pp. 351–359, Mar. 2012.
- [10] EU, "Directive (EU) 2018/2001 of the European Parliament and of the Council on the promotion of the use of energy from renewable sources," *Off. J. Eur. Union*, vol. 2018, no. L 328, pp. 82–209, 2018.
- [11] K. Friansa, I. N. Haq, B. M. Santi, D. Kurniadi, E. Leksono, and B. Yulianto, "Development of Battery Monitoring System in Smart Microgrid Based on Internet of Things (IoT)," *Procedia Eng.*, vol. 170, pp. 482–487, 2017.
- [12] B. Camus, A. Blavette, F. Dufosse, and A.-C. Orgerie, "Self-Consumption Optimization of Renewable Energy Production in Distributed Clouds," in *2018 IEEE International Conference on Cluster Computing (CLUSTER)*, 2018, pp. 370–380.
- [13] C. Zhang, J. Wu, Y. Zhou, M. Cheng, and C. Long, "Peer-to-Peer energy trading in a Microgrid," *Appl. Energy*, vol. 220, pp. 1–12, Jun. 2018.
- [14] A. K. V. S. Sharma, and A. Verma, "Optimal sizing and multi-energy management strategy for PV-biofuel-based off-grid systems," *IET Smart Grid*, vol. 3, no. 1, pp. 83–97, Feb. 2020.
- [15] F. Lezama, J. Palominos, A. Y. Rodríguez-González, A. Farinelli, and E. M. de Cote, "Optimal Scheduling of On/Off Cycles: A Decentralized IoT-Microgrid Approach BT - Applications for Future Internet," in *Applications for Future Internet*, 2017, pp. 79–90.
- [16] P. K. C. Wong, A. Kalam, and R. Barr, "Modelling and analysis of practical options to improve the hosting capacity of low voltage networks for embedded photo-voltaic generation," *IET Renew. Power Gener.*, vol. 11, no. 5, pp. 625–632, Apr. 2017.
- [17] F. Grasso, M. Abdollahi, G. Talluri, and L. Paolucci, "Power Control and Energy Management of Grid-Scale Energy Storage Systems for Smart Users," in *2019 AEIT International Annual Conference (AEIT)*, 2019, pp. 1–6.
- [18] S. Bandyopadhyay, G. R. Chandra Mouli, Z. Qin, L. R. Elizondo, and P. Bauer, "Techno-economical Model based Optimal Sizing of PV-Battery Systems for Microgrids," *IEEE Trans. Sustain. Energy*, pp. 1–1, 2019.
- [19] F. Grasso, M. Abdollahi, G. Talluri, and L. Paolucci, "Techno-Economic Control of Energy Storage System for Demand Side Management," in *2019 AEIT International Annual Conference (AEIT)*, 2019, pp. 1–6.
- [20] D. Azuatalam, M. Förstl, K. Paridari, Y. Ma, A. Chapman, and G. Verbic, *Techno-economic Analysis of Residential PV-battery Self-consumption*. 2018.
- [21] M. Bindu, F. Grasso, A. Luchetta, S. Manetti, and M. C. Piccirilli, "Smart Monitoring and Fault Diagnosis of Joints in High Voltage Electrical Transmission Lines," in *2019 6th International Conference on Soft Computing & Machine Intelligence (ISCMI)*, 2019, pp. 40–44.
- [22] I. Aizenberg, A. Luchetta, and S. Manetti, "A modified learning algorithm for the multilayer neural network with multi-valued neurons based on the complex QR decomposition," *Soft Comput.*, 2012.
- [23] F. Grasso, A. Luchetta, and S. Manetti, "A Multi-Valued Neuron Based Complex ELM Neural Network," *Neural Process. Lett.*, vol. 48, no. 1, pp. 389–401, 2018.
- [24] B. Koffi, A. Cerutti, M. Duerr, A. Iancu, A. Kona, and G. Janssens-Maenhout, "CoM Default Emission Factors for the Member States of the European Union Dataset -Version 2017," European Commission, Joint Research Centre (JRC), p. 13, 2017.
- [25] A. Sgobba and C. Meskell, "On-site renewable electricity production and self consumption for manufacturing industry in Ireland: Sensitivity to techno-economic conditions," *J. Clean. Prod.*, vol. 207, pp. 894–907, Jan. 2019.
- [26] C. Plaza, J. Gil, F. de Chezelles, and K. A. Strang, "Distributed Solar Self-Consumption and Blockchain Solar Energy Exchanges on the Public Grid Within an Energy Community," in *2018 IEEE International Conference on Environment and Electrical Engineering and 2018 IEEE Industrial and Commercial Power Systems Europe (EEEIC / I&CPS Europe)*, 2018, pp. 1–4.
- [27] J. Haapaniemi *et al.*, "Effects of major tariff changes by distribution system operators on profitability of photovoltaic systems," in *2017 14th International Conference on the European Energy Market (EEM)*, 2017, pp. 1–6.